

INSTALLATION INSTRUCTIONS FOR RECESSED CABINETS WITH 12" x 16" OR 15" x 18" DOOR OPENINGS

Note: The following tools are necessary to properly complete this installation:

- small hammer
- vise grip pliers
- 7/16" box wrench
- (2) drift pins: 1/32" and 1/16" diameter
- masking tape

BEFORE PROCEEDING, ENSURE THAT EXISTING RECESSED CABINET IS FIRMLY SECURED TO WALL.

STEP 1: Remove door from existing recessed cabinet

- Apply masking tape above and below the hinge to protect the cabinet while removing the door (**figure 1**).
- With door closed and locked (some American Dispenser Co. units require the door to be open), drive the hinge pin down from the top using a drift pin and hammer. Tap the hinge pin down until it extends approximately 1/8" below the hinge (**figure 2**).
- Grip the bottom of the hinge pin with vise grip pliers and pull down to remove. If the pin does not slide out easily, tap the vise grips lightly with a hammer (**figure 3**).
- Open and remove the door. You may wish to mark the door and cabinet to aid in reinstallation at a later date. Keep the hinge pin with the door.
- Remove the protective masking tape.

STEP 2: Installation of upper mounting bracket – 12" x 16" or 12" x 17" Door openings

- There are two different flange types (square corner "A" or beveled "B") typically found on recessed cabinets (**figure 4**).
- Insert one corner of the appropriate Upper mounting bracket behind the top flange of the recessed cabinet and rotate into position (**figure 5**). Make sure that the bracket is centered above the dispensing opening.

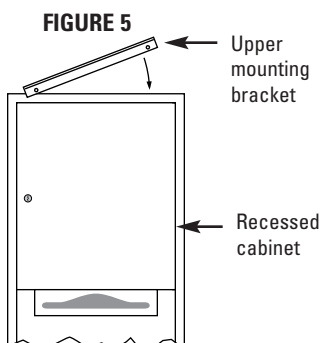
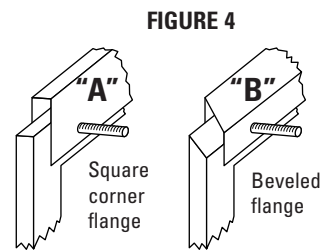
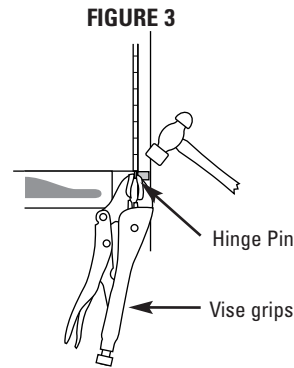
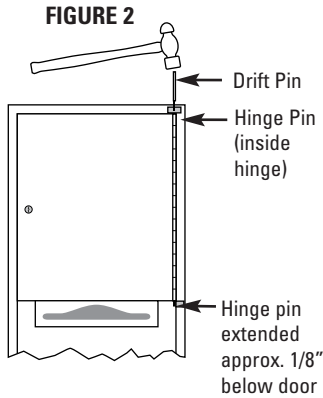
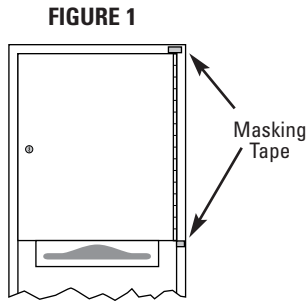

STEP 3: Installation of lower mounting bracket

Note: The procedure for installing the lower mounting bracket varies for units with different size door openings. Be certain to follow the correct procedure.

12" x 16" or 12" x 17" Door Openings

- Position dispenser by aligning top holes in dispenser with threaded studs on the upper bracket. Put the supplied 1/4-20 hex nuts on the two studs and tighten (**figure 6**).
- Insert the 1/4-20 carriage bolt through the center hole in the bottom of the dispenser. Two size carriage bolts (3" and 6") are provided to accommodate various installations.
- Place the "U" bracket on the carriage bolt so that it catches the upper lip of the dispensing opening on the recessed cabinet (**figure 6**).
- Thread the 1/4-20 wing nut onto the carriage bolt and tighten. For a more tamper-resistant installation, install the remaining 1/4-20 hex nut in place of the wing nut.

Note: Only tighten until the dispenser touches the filler panel(s).

DO NOT OVER TIGHTEN.

15" x 18" Door Openings

Note: In this application, the dispenser is installed in a recessed cabinet with a larger door opening and it is necessary to cover, or fill, the open areas before installation. This is accomplished by installing one of three types of filler panels which are available in kit form: (See installation instructions on page 2.)

- For 15" x 18" recessed cabinets with the dispensing opening **CENTERED** in the cabinet (**figure 7**), use "Center Mount Filler Panel Kit", Part No. 10222.
- For 15" x 18" recessed cabinets with the dispensing opening all the way to the **RIGHT** of the cabinet (**figure 8**), use "Left Side Filler Panel Kit", Part No. 10221.
- For 15" x 18" recessed cabinets with the dispensing opening all the way to the **LEFT** of the cabinet (**figure 9**), use "Right Side Filler Panel Kit", Part No. 10562.

Once one of the above filler panels is in place, you may continue with the dispenser installation. Refer to steps A-D and Figure 6, above. (The instructions are the same as for the 12"x16" and 12"x17" Door Openings.)

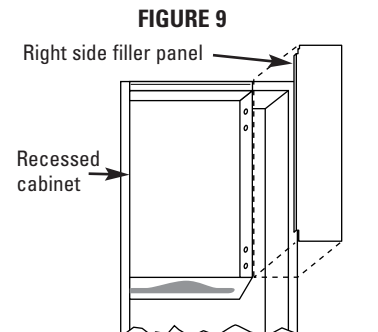
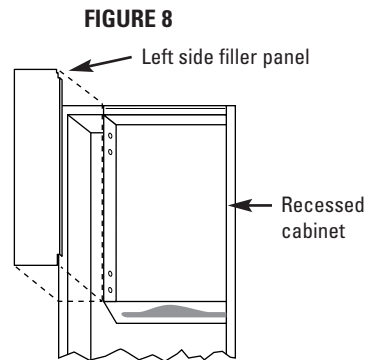
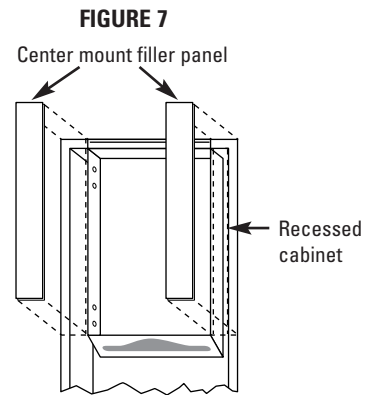
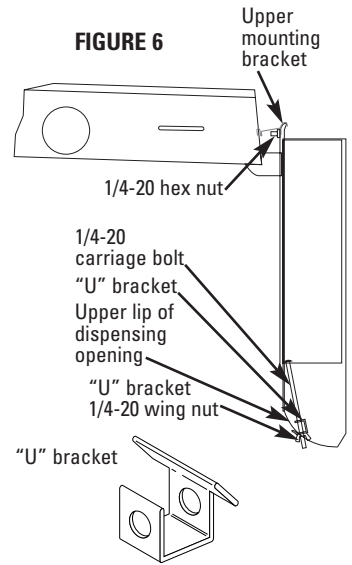

**INSTALLATION INSTRUCTIONS FOR CONVERT-A-MATIC®
DISPENSER OFFSET MOUNT FILLER PANEL KIT
(SPARE PART#10221 and 10562)
(FOR LEFT OR RIGHT FILLER PANELS)**

(To fill the open area on the LEFT when a CONVERT-A-MATIC® Dispenser is installed in an existing recessed cabinet having 15" x 18" door and an offset dispensing opening)

CAUTION – CARE SHOULD BE TAKEN WHILE HANDLING FILLER PANEL DURING INSTALLATION. THE USE OF CLOTH GLOVES IS RECOMMENDED.

1. Remove protective plastic coating from the Filler Panel.
2. Clean all intended mounting surfaces with isopropyl rubbing alcohol. Remove release paper from one side of double sided tape and apply to Filler Panel (figure 1).
3. Remove remaining release paper from tape and install Filler Panel (figure 2).

Note: The wide edge of the Filler Panel must be located INSIDE the area above the throat.

4. Install the appropriate Upper Bracket (provided with Dispenser Mounting Kit) so that the left-hand edge touches the Filler Panel (figure 3).
5. Continue installation as per instructions included with CONVERT-A-MATIC® Dispenser.

FIGURE 1

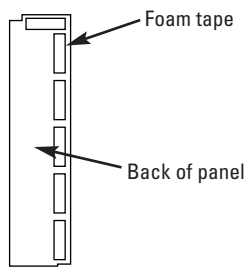

FIGURE 2

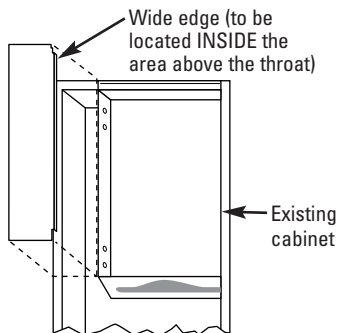
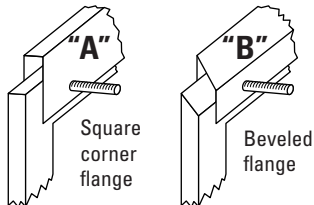
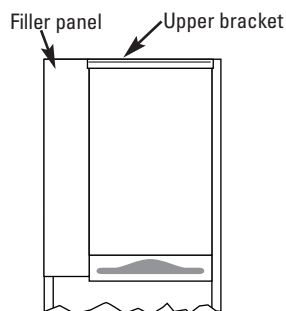

FIGURE 3



AMERICANS WITH DISABILITIES ACT (FOR USE IN U.S. ONLY): Title III of the Americans with Disabilities Act ("ADA") governs, in detail, the placement and operation of dispensers. You should ensure that your mounting and use of dispensers complies with that law as well as the regulations issued under that statute. The mounting suggestions in this document may or may not fulfill the obligations of the ADA with respect to your facility.

KIMBERLY-CLARK CORPORATION DISCLAIMS LIABILITY FOR PERSONAL INJURIES OR PROPERTY DAMAGES RESULTING FROM INSTALLATION NOT PERFORMED BY KIMBERLY-CLARK.

©CONVERT-A-MATIC is a Registered Trademark of Kimberly-Clark Tissue Corporation.
©1999 KCC. All Rights Reserved
Manufactured for: Kimberly-Clark Corporation, Roswell GA 30076

**INSTALLATION INSTRUCTIONS FOR CONVERT-A-MATIC®
DISPENSER CENTER MOUNT FILLER PANEL KIT
(SPARE PART #10222)**

(To fill the open areas remaining when a CONVERT-A-MATIC® Dispenser is installed in an existing recessed cabinet having one 15" x 18" door and a CENTERED dispensing opening)

CAUTION – CARE SHOULD BE TAKEN WHILE HANDLING FILLER PANEL DURING INSTALLATION. THE USE OF CLOTH GLOVES IS RECOMMENDED

1. Before installing filler panels, the "upper bracket" (provided with the dispenser mounting kit) must be in place and centered (figure 1).

Note: To determine if the upper bracket is centered, hold both filler panels in place and check for equal spacing.

2. Remove protective plastic coating from both Filler Panels.
3. Clean all intended mounting surfaces with isopropyl rubbing alcohol. Remove release paper from one side of double sided tape and apply to both Filler Panels (figure 2).
4. Remove remaining release paper from tape and install both Filler Panels (figure 3).

FIGURE 3

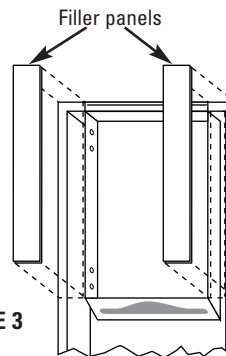

FIGURE 1

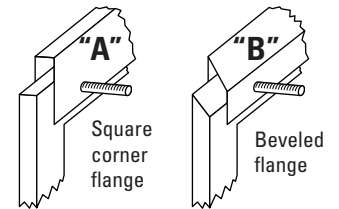
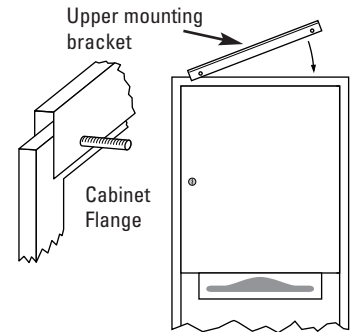

FIGURE 2

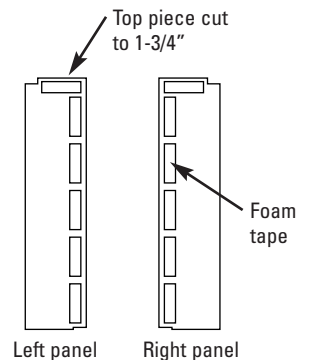
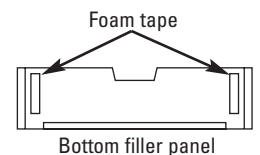

FIGURE 4



5. A. Clean and apply foam tape (figure 4).
B. Remove plastic coating.
C. Slip panel under bottom flange of chassis and press firmly into place (figure 5).

6. A. Check to see that all hardware is securely attached.
B. Install dispensing module by placing the module on the two Module Retaining Tabs and aligning the bottom ribs on the Module with the slots on the back of the housing and slide down to snap in place (figure 6).
C. Load the dispenser with product.
D. Close the cover firmly.
E. Test for proper dispensing.

FIGURE 6

